



SECTION CONTENTS

FEATURES	76
OPERATING PRINCIPLES.....	77
SELECTION	77
AVAILABLE STYLES	78
AVAILABLE TYPES.....	80
OVERLOAD DETECTION	80
SELECTION GUIDE	81

CENTRIC CENTRIFUGAL CLUTCHES

CENTRIC CENTRIFUGAL CLUTCHES CCC SERIES

FEATURES

- Automatic engagement and disengagement
- Delayed engagement produces a “no load start”
- No slippage at full running speed
- Controlled soft-start acceleration
- 100% efficient at rated speed
- Standard, spring control, and deep pocket models
- Protection against shock loads during start-up
- Custom clutches can be designed to be RPM limiters or a “brake” on a runaway system

WHY ARE THEY USED?

The Boston Gear Centric Centrifugal Clutch offers many advantages in motor and engine drive applications. Utilizing the centrifugal clutch enables the selection of normal torque motors for running loads rather than the selection of high torque motors for starting loads. The centrifugal clutch also sharply reduces the motor starting current requirements and heat losses inherent in the direct starting of a drive. This adds up to reduced power factors, greater efficiency and therefore, greater economy in motor drives.

When used with engine drives, the spring controlled centrifugal clutch allows the engine to warm up before starting the load or to stand by at an idling speed. Thus the spring controlled centrifugal clutch is used to great advantage in such applications as dual drives and engine driven pumping systems. This style clutch can also be used with turbines where a warm up period is necessary.



On any drive, the Boston Gear Centric Centrifugal Clutch provides protection against the shock loads which occur in the starting of a rigidly coupled drive. In many cases these loadings are capable of seriously damaging components of the drive and often expensive safety factors have to be designed into the machinery to protect against these loadings. The use of a centrifugal clutch eliminates these possibilities.

The use of a Boston Gear Centric Centrifugal Clutch allows the designer of a particular drive complete flexibility in clutch selection as each clutch is fabricated to order. Friction shoes of specific weights are custom designed therefore, any capacity within a particular clutch size can be obtained. The same holds true in the case of the spring controlled clutch. This style of clutch is designed to provide the specific engagement or disengagement speeds required by a specific application.

STANDARD STYLE

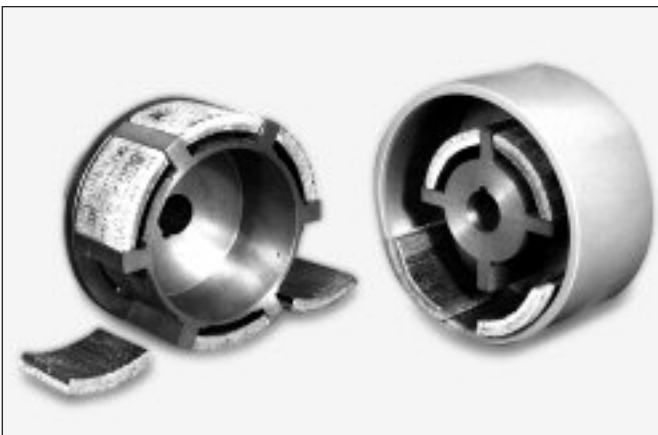

SPRING CONTROLLED STYLE



For application assistance call 704-688-7324 or visit us at www.centricclutch.com

CENTRIC CENTRIFUGAL CLUTCHES

OPERATING PRINCIPLES

The Boston Gear Centric Centrifugal Clutch utilizes two basic force principles in its operation, centrifugal force and friction force. Centrifugal force is that force which tends to pull a rotating body away from its center of rotation. Friction force exists between any two bodies in contact where one of the bodies is trying to move relative to the other body.

Figure 1, a face view of a centrifugal clutch, shows the basic components of the device. The driver half or spider is mounted to the motor or engine shaft and the driven half is connected to the load either directly or by means of some indirect drive arrangement. The friction shoes are the connective element between the driver and driven.

When the drive is set in motion, the spider and the shoes start to rotate. The spider imposes a driving force (F_3) on the friction shoe as shown in Figure 2. The centrifugal force (F_1) developed by the rotary motion of the friction shoe impresses it against the drum creating a frictional force (F_2) between the shoe and the drum.

As the drive increases in speed, the centrifugal force increases and thereby frictional force increases. When the frictional force reaches sufficient magnitude, it overcomes the resistance of the load, and the clutch drives. At full load speed, the shoe is "locked" firmly against the drum and no slippage occurs.

In engine and turbine applications, where it is necessary to "warm up" before attempting to drive a load, a spring controlled clutch is utilized. Figure 3 shows a typical spring control shoe. Here, a flat spring is placed over pins which run through the base of the shoe. This spring is retained in slots which are milled in the legs of the spider creating additional forces (F_s) which are applied to the friction shoes. The thickness of the spring utilized determines at what speed the particular drive may idle while warming up. At this idling speed the centrifugal force (F_1) developed by the rotation is not of sufficient magnitude to overcome the total spring force ($2F_s$) acting in the opposite direction on the friction shoe. As the speed of the drive increases above the point at which the spring forces (F_s) and the centrifugal force (F_1) are balanced, the shoe is pressed against the drum creating a friction force. The operation from this point on is as described above.

SELECTION

There are an infinite number of combinations of Boston Gear Centric Centrifugal Clutches. While operating on the same basic principles, every clutch is designed to suit a specific customer application. To assure that the appropriate clutch is selected, please complete the Selection Guide on Page 81 and fax it to Boston Gear.

Upon receipt, our application engineering department will review your requirements and return the optimal Boston Gear Centric Centrifugal Clutch design along with its dimensional drawings.

FIGURE 1

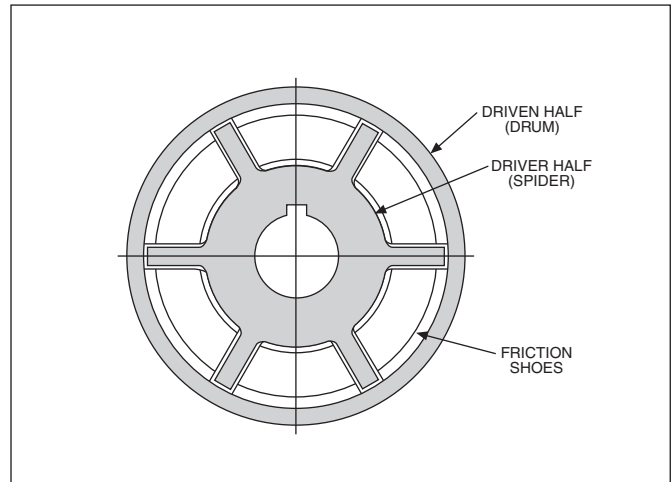

FIGURE 2

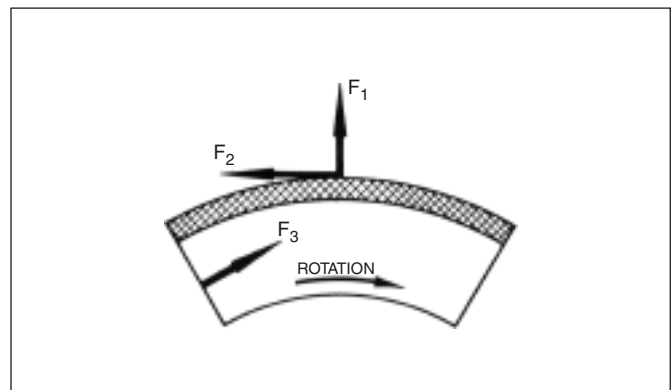
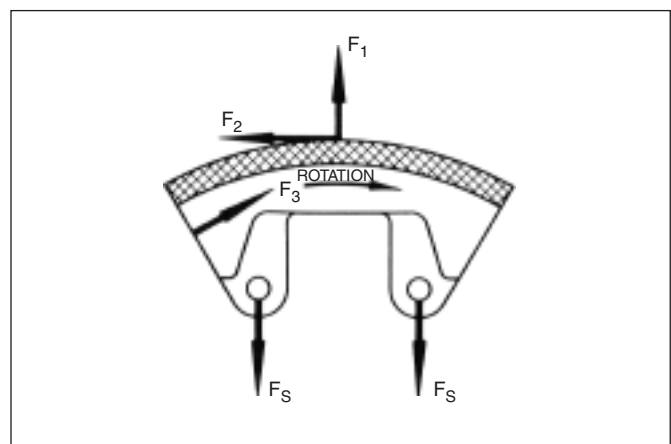

FIGURE 3



CENTRIC CENTRIFUGAL CLUTCHES

AVAILABLE STYLES

Boston Gear Centric Centrifugal Clutches are available for two basic applications: Styles F and J for electric motors and Style L for engines and turbines.

Standard Style F incorporates a shoe arrangement designed for electric motors, (Figure 4). As the motor comes up to speed, the outer friction shoes engage the driven half (the drum) and accelerate it. As it and the load come up to speed, the inner friction shoes engage the driver (the spider) locking up the drive.

**FIGURE 4
STANDARD STYLE F**

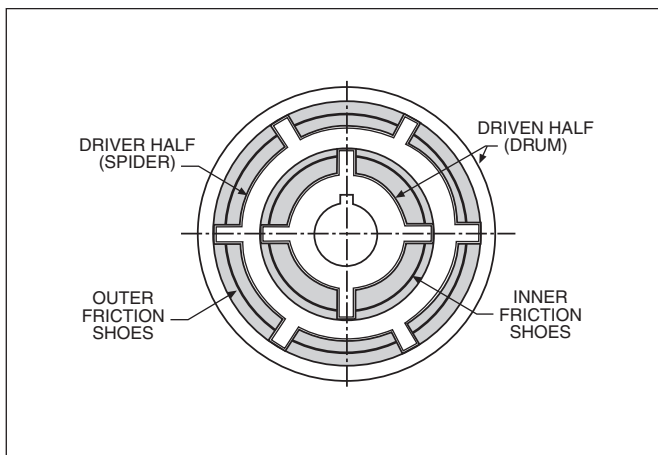

Where overload protection is required or greater capacity is needed in the drive, **Style J** containing deep pockets should be ordered, (Figure 5).

**FIGURE 5
DEEP POCKET STYLE J**

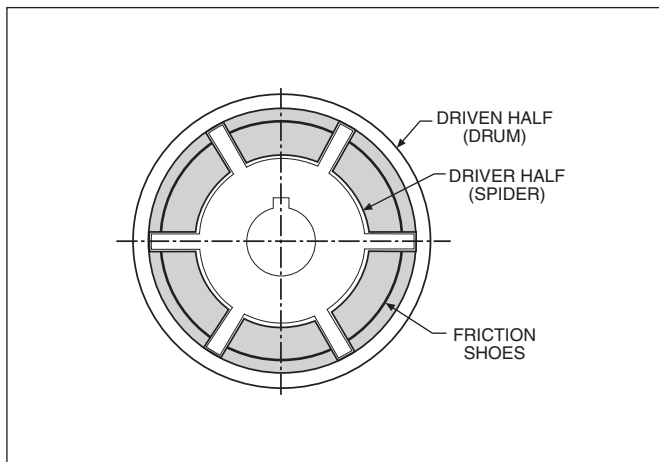

Style L incorporates a spring controlled shoe arrangement designed for engines, turbines, dual drives, or whenever a delayed engagement is desired, (Figure 6).

**FIGURE 6
SPRING CONTROLLED STYLE L**

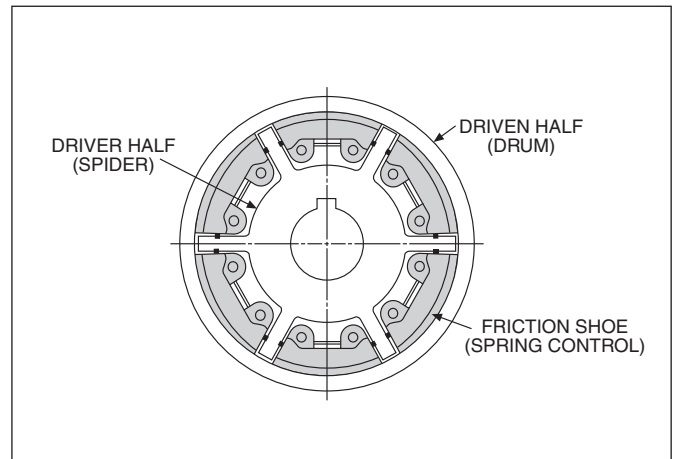

For applications where either high speeds or large horsepower conditions exist, Styles G, K and M may be provided. These styles are identical to the models shown in Figures 4, 5 and 6, however they also incorporate steel bands wrapped around the housing helping to reduce stress, (Figure 7).

**FIGURE 7
STYLE F WITH STEEL BAND**

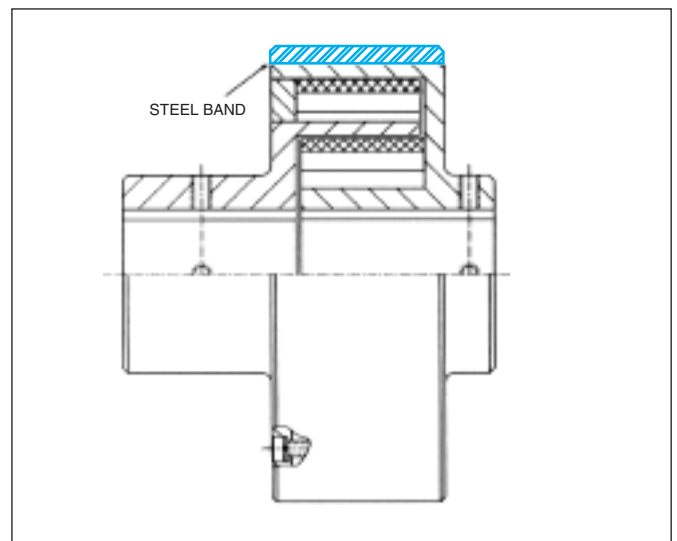

For application assistance call 704-688-7324 or visit us at www.centricclutch.com

CENTRIC CENTRIFUGAL CLUTCHES

TYPE A FREE STYLE AND SPRING-CONTROLLED CENTRIFUGAL CLUTCHES

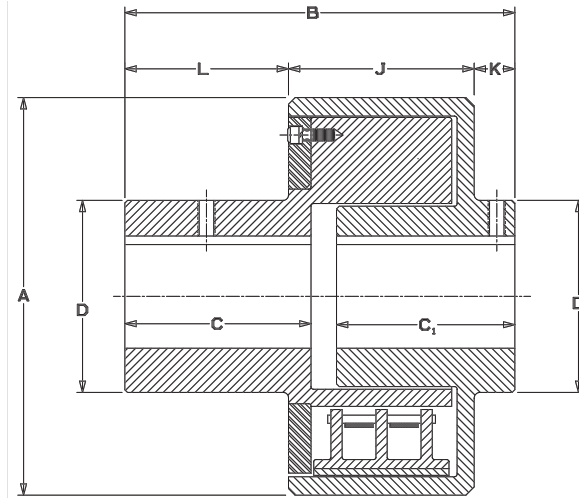

Clutch Coupling Sizes	Maximum Bore Inches	Minimum Bore Inches	Wt. in Lbs. with Max. Bore	DIMENSIONS IN INCHES								
				A	B	C	C ₁	D	J	K	L	HP*
5 x 1-1/2	1-3/8	3/4	15	5-3/8	4-11/16	2-3/16	2-7/16	2-1/2	2-3/16	5/8	1-13/16	40
6 x 2	1-5/8	3/4	25	6-1/2	6-1/4	2-15/16	3-3/16	3	3-1/16	3/4	2-7/16	92
7 x 2-1/2	1-7/8	1	40	7-5/8	7-1/4	3-7/16	3-11/16	3-3/8	3-9/16	3/4	2-15/16	125
10 x 3	2-7/8	1-1/4	100	10-13/16	8-13/16	4-1/8	4-9/16	5-1/8	4-3/16	1	3-5/8	215
12 x 4	3-1/2	1-1/2	200	13-1/8	11-3/8	5-1/2	5-11/16	6-1/4	5-1/2	1	4-7/8	356
16 X 5	4-3/4	2-1/2	400	17-3/8	13-3/4	6-3/4	6-13/16	8-1/2	6-5/8	1	6-1/8	562
24 x 8	7	3	1315	25-1/2	20-3/16	10	10	12-1/2	9-7/8	1-1/16	9-1/4	2280

* The actual horsepower rating is largely dependent on RPM and may be higher or lower than the indicated HP. Contact engineering before finalizing clutch selection.

CENTRIC CENTRIFUGAL CLUTCHES

AVAILABLE TYPES

Type A Centric Centrifugal Clutches are similar to standard coupling/clutch designs in that the installation and removal of the clutch requires horizontal clearance. This type of design may necessitate the relocation of other drive train components to achieve this clearance.

The Type V clutch is a modification of the basic Type A unit. This construction is utilized to a great advantage in direct drive applications where the equipment used is too heavy to be conveniently telescoped at assembly or disassembly. Figure 8 shows how either piece of equipment can be vertically lifted out of its assembled position. The Type V clutch construction allows the clutch spider to be slipped back over its own hub, completely clearing the clutch drum. If a Type A construction had been used here, it would have been necessary to first move the pump horizontally in order to clear the drum and spider before a vertical lift could have been accomplished. This horizontal movement is often not convenient and sometimes impossible such as in certain dual drives and of course where space limitations exist.

**FIGURE 8
VERTICAL LIFTOUT**

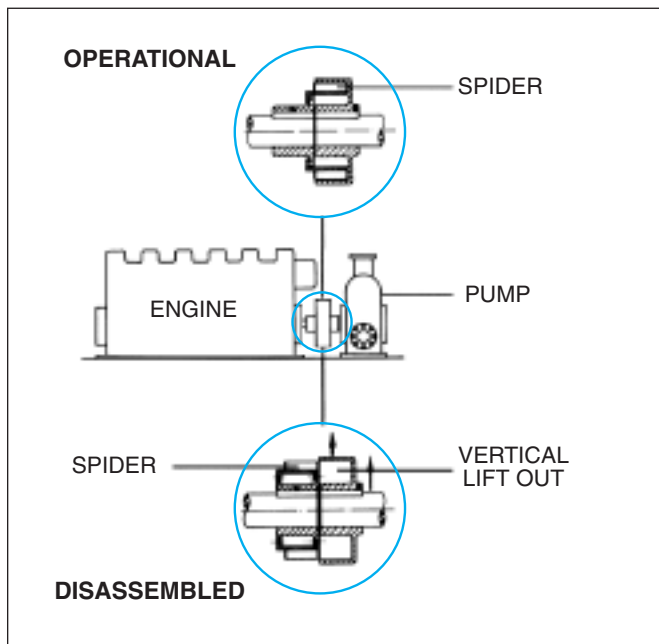

OVERLOAD DETECTION

In Figure 9 a safety device is incorporated to indicate an overload condition. In such applications a centrifugal switch is utilized. The switch is set to trip below a certain critical RPM determined by the application, and in so doing, actuate a signal or shut down the drive. The illustration shows the most common method of using a centrifugal switch in conjunction with a Boston Gear centrifugal clutch. "A" groove sheaves are mounted on the driven member of the clutch and the centrifugal switch. These sheaves are of such a ratio as to allow the centrifugal switch to operate within its limits.

For example, a drive arrangement is set to turn at 1750 RPM. It is determined that the desired cut out speed for the application is at 1500 RPM. The centrifugal switch is set to trip at speeds below 750 RPM and normally will run at 875 RPM which, through a 2:1 ratio corresponds to the drive RPM of 1750.

In actual operation the drive is turning at 1750 RPM. An overload occurs in the driven machinery and the capacity of the clutch is exceeded. While the driver half is still turning at the 1750 RPM, the driven half is dragging due to the increased capacity and drops below the 1500 RPM speed. The switch is actuated by this decrease in speed and an alarm is sounded or the drive is shut down.

FIGURE 9

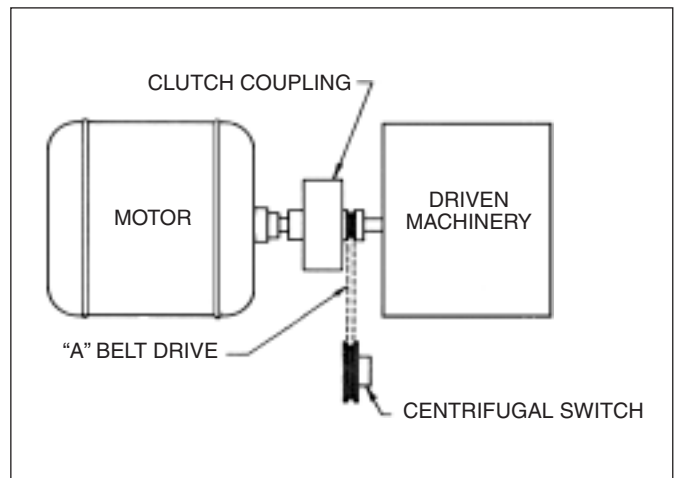

CENTRIC CENTRIFUGAL CLUTCHES

SELECTION GUIDE

To select or order a Boston Gear Centric Centrifugal Clutch, please complete the following information and fax this form to Product Support at 704-688-7403.

GENERAL INFORMATION

Company		
Address	City	State
Contact Person	Tel. No.	Fax No.

APPLICATION DATA

1. Drive method: <input type="checkbox"/> Electric Motor <input type="checkbox"/> Engine/Turbine <input type="checkbox"/> Other
2. Method of drive: <input type="checkbox"/> Direct <input type="checkbox"/> Indirect (provide sketch)
3. Power transmission requirements at clutch location: Horsepower _____ RPM _____
4. Type: <input type="checkbox"/> Standard (A) <input type="checkbox"/> Vertical Lift-Out (V)
5. Speeds (required for engines, turbines, dual drives): Idling _____ RPM Engagement _____ RPM Disengagement _____ RPM
6. Bores: Driver (input) _____ inches Driver (output) _____ inches
7. Service Factor Required: _____

Use the space below to sketch any relevant application data:

